

Dear customer,

Thank you for purchasing an ALFRA product. Please read these operation instructions closely before using your device for the first time and keep them along with the enclosed Product Control Card for later reference.

SAFETY INSTRUCTIONS

Danger can occur when transporting loads by lifting devices due to improper use and/or poor maintenance, which may cause severe accidents and serious injury or even death.

Read and follow the operation and safety information contained in this operating manual very carefully. If you have any questions, contact the manufacturer.

**Always...**

- activate the lifting magnet completely
- activate the lifting magnet on metallic, ferromagnetic materials
- use the entire magnetic surface for lifting
- lift on plane surfaces
- check the magnetic holding force by lifting the load slightly by about 10 cm
- clean the magnetic surface and keep it clear of dirt, chips, welding spatter
- set the lifting magnet down gently to prevent damage to the magnetic surface
- check the hazard area before pivoting the load
- respect the stated maximum load before pivoting
- inspect the magnetic surface and the entire lifting magnet for damage
- use suitable lifting devices
- follow the instructions in the operating manual
- instruct new operators in the safe use of lifting magnets
- respect local and country-specific guidelines
- keep and use in a dry environment

**Never...**

- lift round or arched objects
- exceed the stated maximum load
- lift loads over people
- lift more than one work piece at a time
- switch the lifting magnet off before setting down the load safely
- allow the load to sway or bring to a sharp and immediate stop
- lift loads exceeding the recommended dimensions
- lift loads with cavities, cut-out openings or drilled holes
- lift unbalanced loads
- modify the lifting magnet or remove operating labels
- use the lifting magnet if damaged or missing parts
- strain the underside of the magnet through heavy impact or blows
- position yourself beneath the lifted load
- lift loads while people are within the hazard area
- leave the lifted load unattended
- use the lifting magnet without having been properly instructed
- use if you have not read and understood these operating instructions completely
- use the lifting magnet to support, lift or transport persons
- operate the lifting magnet in temperatures higher than 60°C (140°F)
- expose to corrosive substances



People using pacemakers or other medical devices should not use this lifting magnet until they have consulted with their physician.

PROPER USE

The permanent lifting magnet TML 1000 is designed to lift ferromagnetic, metallic loads and may only be used according to its technical data and determination. Proper use also includes adherence to the start-up, operating, environment and maintenance conditions specified by the manufacturer. Proper use and maintenance of the lifting magnet are the responsibility of the user. It is also his responsibility to understand the Operation Instructions.

DEVICE DESCRIPTION

The TML (Thin Material Lifter) is a switchable lifting magnet with manual actuation for the lifting, transporting and lowering of ferromagnetic materials. By pressing the lever (F) down, the magnetic field generated by the permanent magnet can be activated in the lower magnetic plate (C) area.

Thanks to the special design, a very compact magnetic field is generated which develops excellent adhesive force, especially on thin materials (less than 10 mm). The magnet can be deactivated by first pressing the safety tab (E) with the heel of the hand and then moving the lever upwards. An adjustable oil damper (G) is incorporated underneath the safety tab in order to absorb the recoil energy of the lever, especially during use on thin materials. Additional threads for mounting (H) are located on either front side of the magnet which, if desired, can be used as holding device. An eyelet (A) is situated on the top of the lifting magnet for attachment to a crane. The load-bearing capacity of the lifting magnet is equivalent to 1/3 of the maximum breakaway force of the magnet and thus is equivalent to the standard safety factor 3:1.

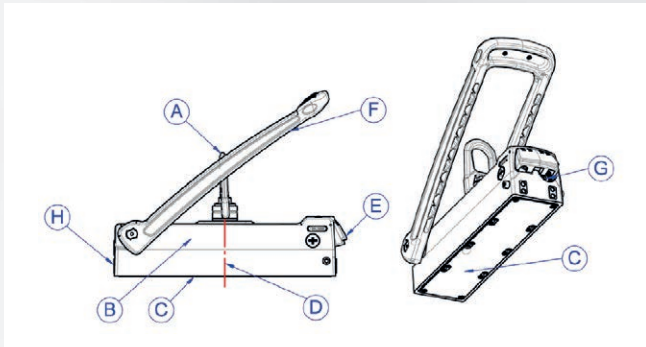

- A) Load hook
- B) Basic body
- C) Magnetic contact area
- D) Center of the magnet
- E) Safety tab
- F) Lever for activation/ deactivation
- G) Shock absorber for lever
- H) Additional threads for mounting

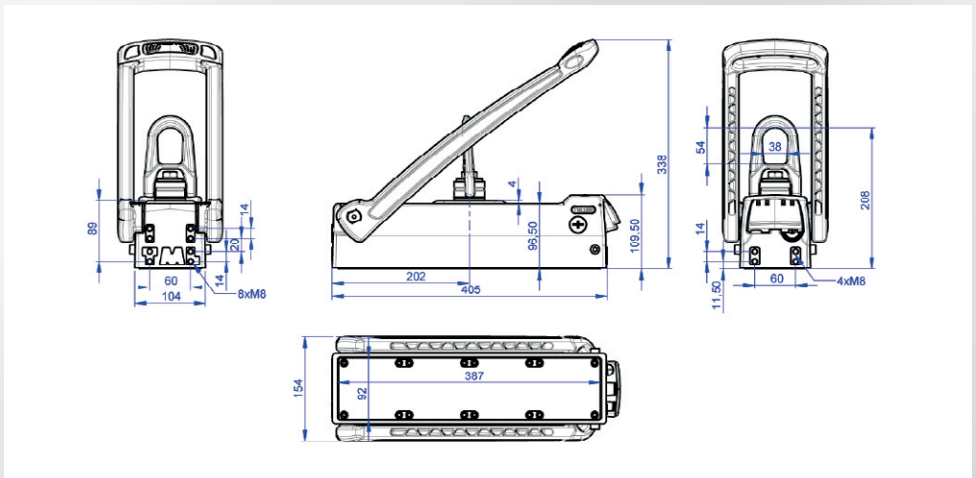

TECHNICAL DATA

Prod.-No.	41700	
Designation	TML 1000 Lifting magnet	
Breakaway force	>3400 kg from 12 mm S235	>7480 lbs from 1/2" AISI CRS 1020
Max. load-bearing capacity: (on flat material with safety factor 3:1)	1000 kg from 12 mm S235	2200 lbs from 1/2" AISI CRS 1020
Max. load-bearing capacity: (at 6° inclination acc. to EN 13155 with safety factor 3:1)	800 kg from 12 mm S235	1760 lbs from 1/2" AISI CRS 1020
Max. load-bearing capacity: (at 90° inclination of the load with safety factor 3:1)	300 kg from 12 mm S235	660 lbs from 1/2" AISI CRS 1020
Dead weight of the magnet	17.9 kg	39.4 lbs
Storage temperature	-30°C to +60°C	-22°F to +140°F
Operating temperature	-10°C to +60°C	+14°F to +140°F

MARKINGS ON THE LIFTING MAGNET

Additional detailed descriptions for handling and operating conditions can be found on both sides of the lifting magnet. This labeling must not be modified, damaged or removed, as otherwise the manufacturer cannot be held responsible for any personal injuries, property damage or accidents resulting from this fact. New labels must be ordered from the manufacturer if necessary.

TML1000

Passion for Tools

Alfra GmbH
 Il. Industriestr. 10 - 88766 Hockenheim
MADE IN GERMANY

**Max.
1000 kg
2200 lbs**
 Unit: 17.9 kg | 39.4 lbs
 EN 13155 €€

mm	kg	inch	lbs
3	220	0.12	480
4	370	0.16	810
5	500	0.20	1100
6	622	0.25	1365
8	825	0.30	1815
10	975	0.40	2145
12	1000	0.45	2200
15	1000	0.60	2200
20	1000	1.00	2200

1000 kg @ 12 mm S235
2200 lbs @ 1/2" Steel

800 kg @ 6°
1760 lbs @ 6°

300 kg @ 90°
660 lbs @ 90°

ON → PRESS → OFF

2006/42/EG | EN ISO 12100 | EN 13155 **CE**

Luftspalt Air gap	mm	0,0	0,2	0,4	0,6	1,0	1,5
	inch	0,0	0,008	0,016	0,024	0,039	0,059
		100%	86%	74%	66%	50%	36%

60°C
-10°C
140°F
14°F

START-UP

You have received a completely assembled lifting magnet and detailed operating manual. Please check the condition of the goods upon receipt for any damage incurred during transport, and make sure the delivery is complete. If you have any problems, please contact the authorized reseller or manufacturer immediately.



Be sure to read the operation instructions completely before using this magnet for the first time!

1. The lever is facing upwards. The lifting magnet is deactivated.
2. Follow the safety instructions. Clean the work piece and the lower magnetic plate of the lifting magnet.
3. Position the lifting magnet at the center of gravity of the load. The lifting magnet is pre-tensioned slightly in order to avoid inadvertent slipping and dropping of the magnet (e.g. when used in a vertical or other forced position).
4. Align the lifting magnet ideally according to the desired application.
5. Press the lever down until it is fully engaged in the ON position. Make sure that the safety tab is securely locked in place.
6. Move the load hook to the required position and lift the load by about 10 mm to check its deformation and the magnetic holding force.
7. Now move your load slowly and smoothly. Avoid swinging or jarring.
8. After the load has been set down completely and safely, you can deactivate the lifting magnet. To do this, press the safety tab using the heel of your hand and move the lever upwards into the OFF position.

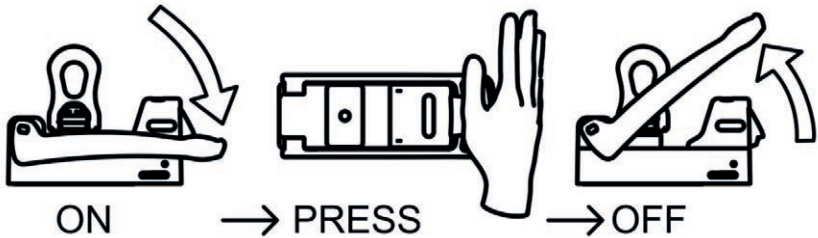

PIVOTING OR VERTICAL LIFTING OF LOADS

The special design of the TML1000 lifting magnet allows the user to turn and pivot the load freely. The suspended load can be turned around at 360° and pivoted at 90° in most cases.

1. Be sure to use a flexible soft eye to avoid jamming the lifting magnet into the hook of the crane since this would lead to extremely unfavorable load conditions and the lifting capacity would no longer be assured. In addition, this will protect your magnet from damage and extend its lifetime.

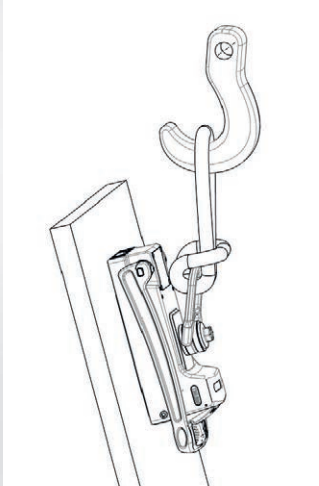

Figure 1

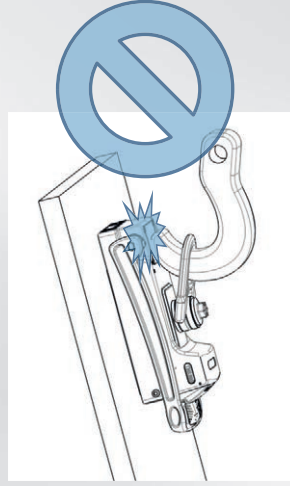
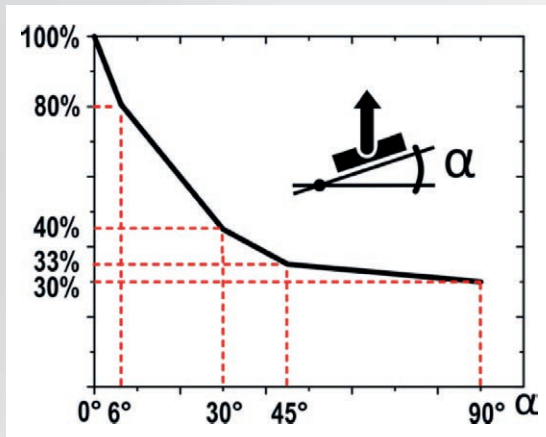

Figure 2

2. If the load is attached horizontally to the magnet, the entire breakaway force of the lifting magnet is acting on the load, so you can use 100 % of the lifting capacity as stated in table 2. However, if the load and the magnet surface tilt at an angle other than 0° to horizontal, the load-bearing capacity decreases due to the new alignment of the magnet to the gravity of Earth. As soon as the load is suspended vertically, i.e. at an angle of 90°, friction will be the only effect exerted by the magnet which is not more than 10-35 % of the maximum load-bearing capacity, depending on material being lifted.



Load-figures corresponding to the direction of the TML 1000

You can calculate the maximum load-bearing capacity of your magnet, including the 3:1 safety factor, on the basis of the load-figure that corresponds to the direction.

Example mm:

You would like to lift a plate which is 6 mm thick and made of S235. The plate stands vertically, i.e. at an angle of 90°, in your shelf rack and your magnet is ideally positioned, as shown in figure 1.

Material thickness: 6 mm → max. load-bearing capacity at 0° = 622 kg (see table 2)
Material: S235 → holding force, subject to material = 100% (see table 1)
Alignment of the load: 90° tilted; load hook facing upwards
→ Load-figure corresponding to direction = 30%

Example INCH:

You would like to lift a plate of mild Cold Rolled Steel (CRS) which is 1/4 inch thick. The plate stands vertically, i.e. at an angle of 90°, in your shelf rack and your magnet is ideally positioned, as shown in figure 1.

Material thickness: 1/4 inch → max. load-bearing capacity at 0° = 1365 lbs (see table 2)
Material: mild steel → holding force, subject to material = 100% (see table 1)
Alignment of the load: 90° tilted; load hook facing upwards
→ load-figure corresponding to direction = 30%

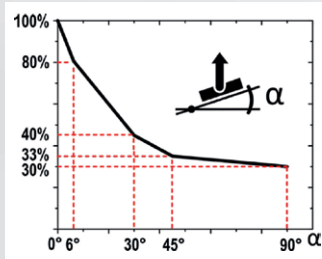
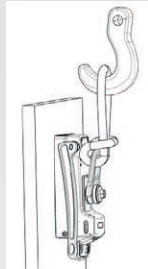

Maximum load weight with 3:1 safety factor = 622 kg x 100% x 30% = 186 kg

Maximum load weight with 3:1 safety factor = 1365 lbs x 100% x 30% = 410 lbs

ADJUSTABLE SHOCK ABSORBER

An oil filled shock absorber is incorporated on the backside of the magnet in order to absorb any recoil energy of the lever. The thinner the material to be lifted the higher the recoil energy to be absorbed. The set screw on the backside of the magnet makes it possible to adjust the shock absorber variably, so that the upward movement of the lever is controlled and operates smoothly. This adjustment should be made by using a flat-blade screwdriver.

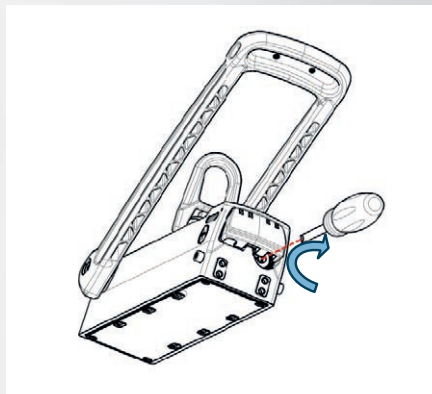

BASIC INFORMATION CONCERNING THE HANDLING OF MAGNETIC LIFTING GEAR, IN PARTICULAR TML

The magnetic surface is located on the underside of the lifting magnet incorporating multiple magnetic poles which generate the magnetic holding force when activated. The maximum holding force that can be achieved depends on different factors which are explained below:

Material thickness

The magnetic flux of the lifting magnet requires a minimum material thickness to flow completely into the load. Below this minimum thickness of material, the maximum holding force is reduced subject to material thickness. Conventional switchable permanent magnets have a deep penetrating magnetic field similar to tree tap roots, and require a large material thickness to achieve maximum holding force. The compact magnetic field of the TML magnets is similar to a shallow root and achieves maximum holding force even when used on thin materials (see table 2 in this operating manual).

Material

Every material reacts in a different way to penetration of the magnetic field lines. The load-bearing capacity of the lifting magnets is determined using low carbon material. Steels with high carbon content or whose structure has been changed by heat treatment have a lower holding force. Foamed or porous cast components also have a lower holding force, so that the given load-bearing capacity of the lifting magnet can be downgraded on the basis of the following table1.

Table 1

Material	Magnetic force in %
Non-alloyed steel (0.1-0.3% C content)	100
Non-alloyed steel (0.3-0.5% C content)	90-95
Cast steel	90
Grey castiron	45
Nickel	11
Most stainless steels, aluminium, brass	0

Surface quality

The maximum holding force of a lifting magnet can be achieved in case of a closed magnetic circuit in which the magnetic field lines can connect up freely between the poles, thus creating a high magnetic flux. In contrast to iron, for example, air has very high resistance to magnetic flux. If a kind of "air gap" is formed between the lifting magnet and the work piece, the holding force will be reduced. In the same way, paint, rust, scale, surface coatings, grease or similar substances all constitute a space, or an air gap, between work piece and lifting magnet. An increase in surface roughness or unevenness also has an adverse effect on the magnetic holding force. Reference values can be found in the performance table of your lifting magnet.

Load dimensions

When working with large workpieces such as girders or plates, the load can deform during the lift. A large steel plate would bend downwards at the outer edges and create a curved surface which no longer has full contact with the bottom of the magnet. The resulting air gap reduces the maximum load-bearing capacity of the lifting magnet. Hollow objects or those smaller than the magnetic surface will also result in less holding power being available.

Load alignment

During load transport, care must be taken that the lifting magnet is always at the center of gravity of the work piece and that load, or lifting magnet respectively, is always aligned horizontally. In this case, the magnetic force of the lifter acts with its breakaway force perpendicular in relation to the surface, and the maximum rated load-bearing capacity is achieved with the 3:1 standard safety factor.

If the position of work piece and lifting magnet changes from horizontal to vertical, the lifting magnet is operated in shear mode and the work piece can slip away to the side. In shear mode, the load-bearing capacity decreases dependent upon the coefficient of friction between the two materials.

Temperature

The high-power permanent magnets installed in the lifting magnet will begin to lose their magnetic properties irreversibly from a temperature of more than 80°C (180°F), so that the full load-bearing capacity is never reached again even after the magnet has cooled down. Please note the specifications on your product or in the operating manual.

MAINTENANCE AND INSPECTION OF THE LIFTING MAGNET

The user is obliged to maintain and service the lifting magnet in compliance with the specifications in the operating manual and according to the country-specific standards and regulations (e.g. ASME B30.20B, DGUV-Information 209-013; AMVO).

The maintenance intervals are classified according to the recommended schedule.

Before every use...

- visually inspect the lifting magnet for damage
- clean the surface of the workpiece and the underside of the magnet
- free the underside of the magnet of rust, chips or unevenness
- verify the lock function of the safety tab on the lever

Weekly...

- inspect the lifting magnet and load hook for deformation, cracks or other defects
- make sure that the operating lever and safety tab are working properly
- inspect the load hook for damage or wear and have it replaced if necessary
- inspect the bottom of the magnet for scratches, pressure points or cracks and have the magnet repaired by the manufacturer if necessary

Monthly...

- check the markings and labelling on the lifting magnet for legibility and damage and replace them if necessary

Annually...

- have the load-bearing capacity of the lifting magnet checked by the supplier or an authorized workshop
- inspect the load hook thoroughly for damage, cracks or wear and have it replaced if necessary

After 5 years or 20.000 lifting operations

- After a maximum of 5 years or 20.000 lifting operations the load hook must be replaced with a new one by the manufacturer or an authorized workshop (thread locking adhesive, mediumstrength; 100 Nm torque).

An annual inspection is recommended for the safe use of this lifting magnet.
We will be glad to perform this inspection for you in-house.
Please send us an email to:

TML-Test@alfra.de

You will then promptly receive an offer and have the assurance that the lifting magnet will be inspected in a process-reliable manner where it was actually produced.



**Unauthorized repairs or modification to the lifting magnet are not permitted.
If you have any questions contact the manufacturer.**

DETAILED PERFORMANCE DATA FOR THE TML 1000 LIFTING MAGNET

Values shown for load capacity are based on material S235 JR comparable to AISI 1020 Cold Rolled Steel with the maximum, vertical breakaway force at 0° deviation from the load axis and additionally under a 6° inclined load in accordance with EN13155, in each case with a 3:1 safety factor. This manual does not contain any instructions for use on round material, as the TML 1000 is designed for flat material and round material or arched objects may not be lifted.

Table 2

Load capacity in kg						
Thickness of material	Clean, flat, ground surface		Rusty, slightly scratched surface		Irregular, rusty or rough surface	
	Air gap <0.1 mm		Air gap = 0.2 mm		Air gap = 0.6 mm	
mm	0°	6°	0°	6°	0°	6°
3	220	178	180	145,8	140	113
4	370	300	330	267,4	280	227
5	500	405	450	364,6	380	308
6	622	504	550	445,6	445	361
8	825	668	705	571,2	530	429
10	975	790	830	672,5	580	470
12	1000	810	865	700,9	590	478
15	1000	810	865	700,9	610	494
>20	1000	810	865	700,9	610	494

Load capacity in lbs						
Thickness of material	Clean, flat, ground surface		Rusty, slightly scratched surface		Irregular, rusty or rough surface	
	Air gap <0.004 inches		Air gap = 0.008 inches		Air gap = 0.022 inches	
inch	0°	6°	0°	6°	0°	6°
0,12	480	392	396	321	308	250
0,16	810	660	726	588	616	499
0,20	1100	891	990	802	836	677
0,25	1365	1109	1210	980	979	793
0,30	1815	1471	1551	1257	1166	945
0,40	2145	1738	1826	1480	1276	1034
0,45	2200	1783	1903	1542	1298	1052
0,60	2200	1783	1903	1542	1342	1087
>1	2200	1783	1903	1542	1342	1087

The maximum dimensions of the loads to be lifted depend to a large extent on the geometry and flexural stiffness of the work pieces. If the material bends, an air gap will form under the magnetic surface which will decrease the load-bearing capacity significantly. During each lift, watch for any deformation of the work piece that might occur and, if necessary, check for any air gap developing at the edges of the TiN-coated magnetic surface (e.g. with a sheet of paper; 80g/m²). Spreader bars with additional magnets may be required to safely lift large or flexible loads.

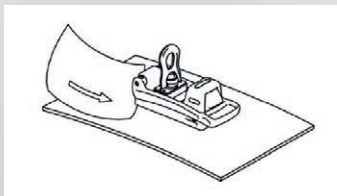

Immediately stop the lift if there is any excessive deformation or an air gap.



Never exceed the dimensions and/or the load-bearing capacity of the material thickness given in the table 2.

EC DECLARATION OF CONFORMITY AS DEFINED BY THE MACHINERY DIRECTIVE 2006/42/EC

We,

Alfra GmbH
2. Industriestr. 10
68766 Hockenheim/Germany

hereby declare that the switchable permanent magnet-type lifting magnet **TML 1000**
from serial number **18K84000256** onwards

complies with all relevant provisions of this directive.

Applied standards:

EN ISO 12100:2010
EN 13155:2003+A2:2009

This certificate is no longer valid if the product is modified without the manufacturer's consent.
Furthermore, this certificate is no longer valid if the product is not used properly in accordance with the use cases documented in the user manual or if regular maintenance is not carried out in accordance with this manual or country-specific regulations.

Person authorized to compile the documents:

Alfra GmbH
2. Industriestr. 10
68766 Hockenheim/Germany

Hockenheim/Germany, 28.02.2018

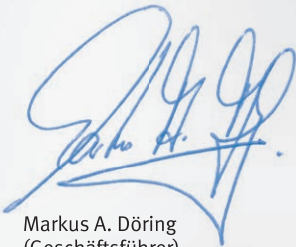

Markus A. Döring
(Geschäftsführer)



Certificate No. Z1 18 03 04087 001