

Entertainment Grade-8 Eyenuts

User Guide

- Designed for the entertainment industry
- Forged From High Tensile Alloy Steel
- Tempered
- Black Zinc Low Sheen Matt Finish for low visibility applications
- Manufactured from Steel certified to Australian Standards
- Electromagnetic crack testing to AS 1171
- Special thread forms made to order

Please ensure that all information contained in this user guide has been read and understood prior to the safe use of the Grade-8 Lifting Eyenut. Failure to follow this guide may result in serious injury and/or property damage. Failure to follow this user guide voids the manufacturer's warranty.

This document may refer to the Eyenut as the Lifting Point.

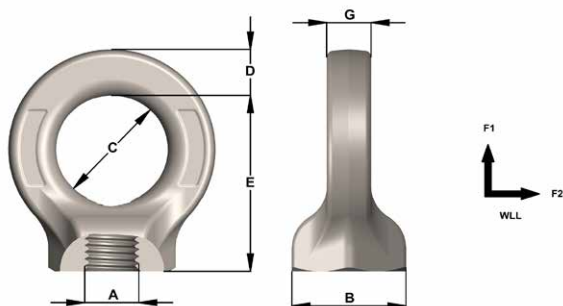

Townley Drop Forge maintains a NATA Accredited Laboratory (Test Lab No. 13554) and an AS/NZS ISO9001 Certified QMS (Certificate number FS 604897).

A Imperial	A Metric	WLL F1	WLL F2	B	C	D	E	G	Weight (kg)
3/8"	M10	1t	0.25t	27	30	12	48	10	0.17
1/2"	M12	1.6t	0.4t	27	30	12	48	10	0.17
5/8"	M16	4t	1t	34	34	15	56	14	0.37
3/4"	M20	6t	1.6t	41	40	17	70	16	0.6
7/8"	M22	7t	2t	50	50	20	85	18	1.1
1"	M24	8t	2.5t	50	50	20	85	18	1.1

WLL (WORKING LOAD LIMIT)

Each Eyenut is clearly stamped with the permitted F2 WLL.

F2 WLL - indicates safe use for non-axial lifts.

F1 WLL - indicates loads which are in line with the axis of the threaded end of the eyenut. F1 WLL allows up to four (4) times higher lifting capacity whilst maintaining a 4:1 design factor of safety.