

ALFRA TML 90 R



Passion for Tools

- DE LASTHEBEMAGNET
- EN LIFTING MAGNET
- FR AIMANT DE LEVAGE
- ES IMÁN DE ELEVACIÓN DE CARGAS
- NO LØFTEMAGNET

 **MADE IN GERMANY**



US Patent Nr. 8350663B1



ALFRA TML 90 R #41100.L.R.

BEDIENUNGSANLEITUNG
OPERATION MANUAL | MODE D'EMPLOI | MANUAL DE INSTRUCCIONES | BRUKSANVISNING

Dear customer,

Thank you for purchasing an ALFRA product. Please read these operation instructions closely before using your device for the first time and keep them along with the enclosed Product Control Card for later reference.

SAFETY INSTRUCTIONS

Dangers can occur when transporting loads by lifting devices due to improper handling and/or poor maintenance, which may cause serious accidents with fatal physical injuries. Please read these operation instructions closely and observe all safety instructions mentioned therein. Contact the manufacturer if you have any questions.

**Always...**

- activate the lifting magnet completely
- activate the lifting magnet on metallic, ferromagnetic materials
- use the entire magnetic surface for lifting
- lift on plane surfaces
- lift round pipes with the correct diameter
- ensure that the pipe is positioned correctly in the groove when using the lifting magnet on round pipes
- check the magnetic holding force by lifting the load slightly by about 10 cm
- clean the magnetic surface and keep it clear of dirt, chips and welding sputter
- set the lifting magnet down gently to prevent damage to the magnetic surface
- check the hazard area before pivoting the load
- respect the stated maximum load before pivoting
- inspect the magnetic surface and the entire lifting magnet for damage
- use suitable lifting gear
- follow the instructions in these operating instructions
- instruct new operators to the safe use of lifting magnets
- respect local, country-specific guidelines
- store in a dry place

**Never...**

- exceed the stated maximum load
- lift arched objects or objects with free form surfaces
- lift round pipes of a too big or too small diameter
- lift load over people
- lift more than one work piece at a time
- switch the lifting magnet off before setting down the load safely
- allow the load to sway or bring to a sharp and immediate stop
- lift loads exceeding the recommended dimensions
- lift loads with cavities, cut-out openings or drilled holes
- lift unbalanced loads
- modify the lifting magnet or remove operating labels
- use the lifting magnet if damaged or missing parts
- strain the underside of the magnet through heavy impact or blows
- position yourself beneath the lifted load
- lift loads while people are within the hazard area
- leave the load hanging unattended
- use the lifting magnet without having been properly instructed
- use if you have not read and understood these operating instructions completely
- use the lifting magnet to support, lift or transport persons
- operate the lifting magnet in temperatures higher than 60°C (140°F)
- expose to corrosive substances



People using pacemakers or other medical devices should not use this lifting magnet until they have consulted with their physician.

PROPER USE

The permanent lifting magnet TML 90 R is designed to lift ferromagnetic, metallic loads and may only be used according to its technical data and determination. Proper use includes adherence to the start-up, operating, environment and maintenance conditions specified by the manufacturer. The user bears sole responsibility for understanding the operating manual as well as for proper use and maintenance of the lifting magnet.

DEVICE DESCRIPTION

The TML 90 R (Thin Material Lifter) magnet is a switchable lifting magnet with manual actuation designed to lift and transport ferromagnetic materials. To activate the magnet, push the activation lever (A) into the ON position until it audibly latches into place. The installed permanent magnet (B) generates a magnetic field in the lower magnetic plate area (D). Owing to the special design of the TML 90 R, this magnetic field is very compact and develops excellent adhesive force especially on thin materials of less than 10 mm. Care must be taken that the lever springs back when working on thin materials. The activation lever must be lifted slightly at its end and returned by 60° into the OFF position to deactivate the magnet.

A rotatable and pivotable load swivel (C) is situated on the top of the lifting magnet. This load swivel can be used with a soft eye to attach the lifting magnet to the hook of a crane. The load-bearing capacity of the lifting magnet is equivalent to 1/3 of the maximum breakaway force of the magnet and thus complies with the standard safety factor of 3:1.

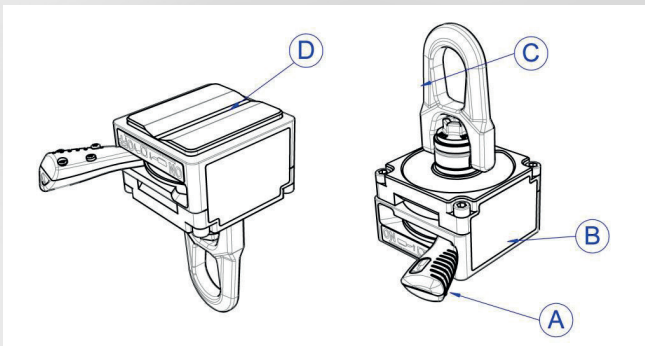

- A) Activation lever
- B) TMC 300 R Magnetic base (41100.R)
- C) Rotatable load swivel
- D) Magnetic surface

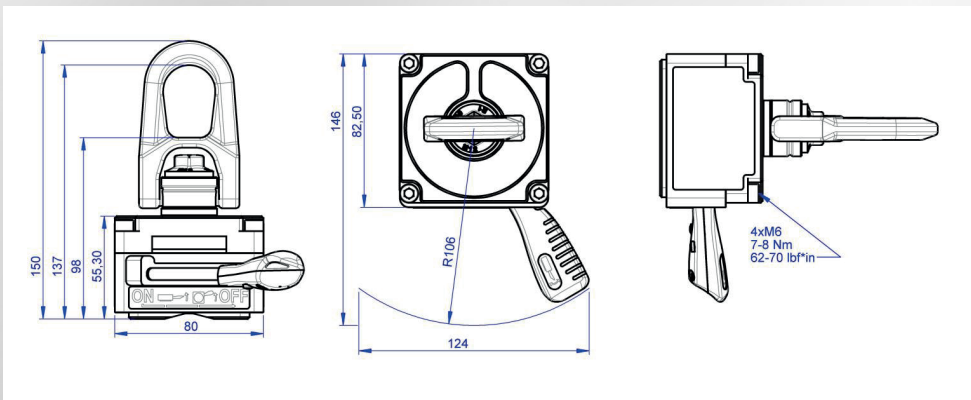

Be sure to read the operation instructions completely before using this magnet for the first time!

TECHNICAL DATA

Prod.-No.	41100.L.R	
Designation	TML 90 R Lifting magnet	
Breakaway force	>270 kg from 6 mm S235	>594 lbs from 0,25"
Max. load-bearing capacity: (on flat material with safety factor 3:1)	90 kg from 6 mm S235	200 lbs from 0,25"
Max. load-bearing capacity: (at 6° inclination acc. to EN 13155 with safety factor 3:1)	81 kg from 6 mm S235	178 lbs from 0,25"
Max. load-bearing capacity: (at 90° inclination of the load with safety factor 3:1)	30 kg from 6 mm S235	66 lbs from 0,25"
Max. load-bearing capacity: (on round pipes at 0° inclination)	20 - 50% of the load-bearing capacity for flat material	20 - 50% of the load-bearing capacity for flat material
Admissible diameter of round pipes	25 - 200 mm	1" - 8"
Dead weight of the unit	1,8 kg	3,9 lbs
Storage temperature	-30°C to +60°C	-22°F to +140°F
Operating temperature	-30°C to +60°C	-22°F to +140°F

MARKINGS ON THE LIFTINGMAGNET

Detailed descriptions for the safe handling and proper operating conditions of the TML 90R can be found on both sides and on top of the lifting magnet. This labeling must not be modified, damaged or removed. Otherwise the manufacturer cannot be held responsible for any personal injuries, property damage or accidents resulting from this fact. New labels must be ordered from the manufacturer if necessary.

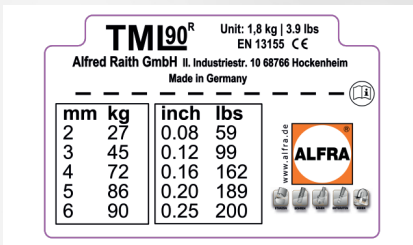

Prod.-No.: 189414233.R

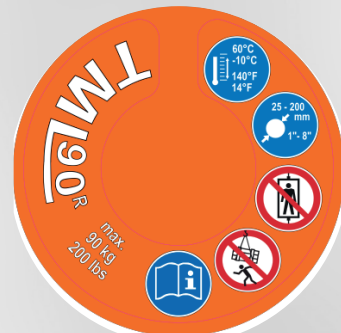

Prod.-No.: 189414232.R

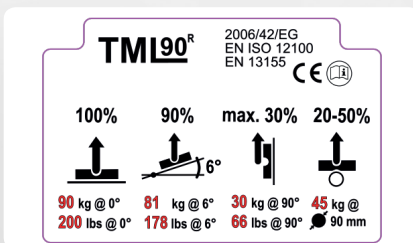

Prod.-No.: 189414234.R

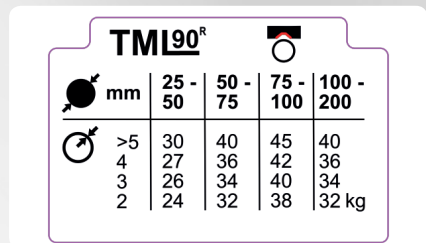

Prod.-No.: 189414237.R

START-UP

You receive a completely assembled lifting magnet and a detailed operating manual. Please check the condition of the goods upon receipt for any damage incurred during transport, and make sure the delivery is complete. If you have any problems, please contact the manufacturer immediately.

1. Follow the safety instructions. Clean the workpiece and the lower magnetic plate of the lifting magnet.
2. Position the lifting magnet at the centre of gravity of the load. The lifting magnet is pre-tensioned slightly in order to avoid inadvertent slipping and dropping of the magnet (e.g. when used in a vertical or other forced position).
3. Align the lifting magnet according to the desired application.
4. Turn the activation lever by 60° into the ON position until it audibly latches into place (with a slight tilting).
5. Move the load hook to the required position and lift the load by about 10 mm to check its deformation and the magnetic holding force.
6. Now move your load slowly and smoothly. Avoid swinging or jarring.
7. After the load has been set down completely and safely, you can deactivate the lifting magnet. To do this, push the activation lever at its far end upwards (1.) and move it into the OFF position (2.).

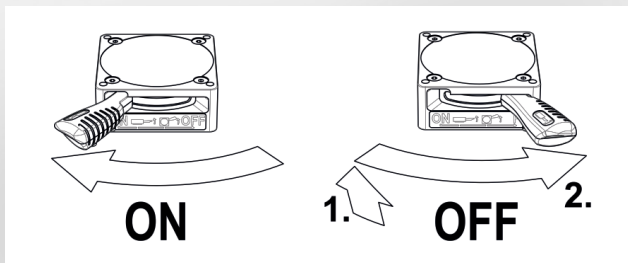

The maximum dimensions of the loads to be lifted depend to a large extent on the geometry and flexural stiffness of the work pieces. This is due to the fact that, in case of bending, an air gap forms under the magnetic surface resulting in a significant decrease of the load-bearing capacity. During each lift, watch for any deformation of the work piece that might occur. If necessary, check for any air gap developing at the edges of the TiN-coated magnetic surface (e.g. with a sheet of paper; $80\text{g}/\text{m}^2$).

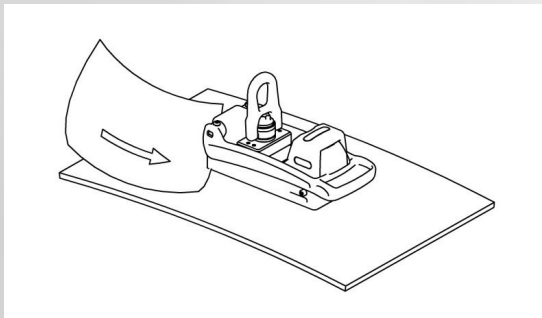

Immediately stop the lift if there is any excessive deformation or an air gap.



Never exceed the dimensions and/or the load-bearing capacity of the material thickness given in table 2 & 3.

PIVOTING OR VERTICAL LIFTING OF LOADS

The special design of the TML 90 R lifting magnet allows the user to turn and pivot the load freely. The suspended load can be turned around at 360° and pivoted at up to 90°.

1. Be sure to use a flexible soft eye to avoid jamming the lifting magnet into the hook of the crane. Otherwise this leads to extremely unfavorable load conditions and the lifting capacity would no longer be assured. In addition, you protect your magnet from damage and extend his lifetime by using a soft eye.

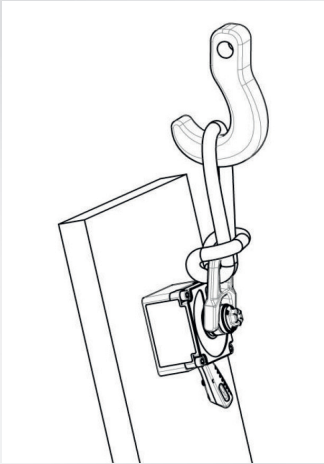

Figure 1

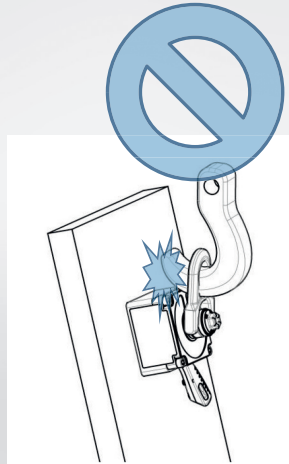
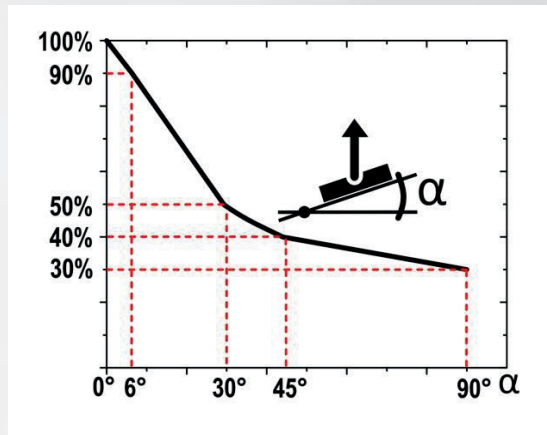

Figure 2

2. If the load is attached horizontally to the magnet, the entire breakaway force of the lifting magnet is acting on the load, so you can use 100% of the lifting capacity as stated in table 2. However, if load and magnet surface tilt at an angle other than 0° to horizontal, the load-bearing capacity decreases due to the new alignment of the magnet to the gravity of Earth. As soon as the load is suspended vertically, i.e. at an angle of 90°, friction will be the only effect exerted by the magnet which is not more than 10 - 35 % of the maximum load-bearing capacity, depending on the material being lifted.



Load-figures corresponding to the direction for the TML 90 R

You can calculate the maximum load-bearing capacity of your magnet, including the 3:1 safety factor, on the basis of the load-figure that corresponds to the direction.

Example:

You would like to lift a plate of S235 which is 6 mm thick. The plate stands vertically in your shelf (i.e. at an angle of 90°) and your magnet is ideally positioned, as shown in figure 1.

Material thickness: 6 mm → max. load-bearing capacity at 0° = 90 kg (see table 2)

Material: S235 → holding force, subject to material = 100 % (see table 1)

Alignment of the load: 90° tilted; load swivel facing upwards

→ Load-figure corresponding to direction = 30 %

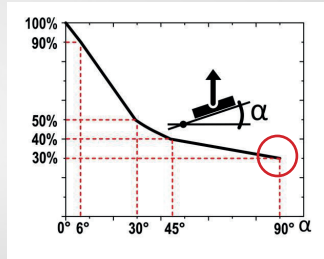
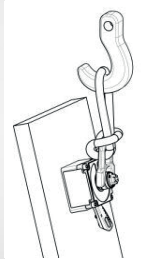

Maximum load weight with 3:1 safety factor = 90 kg x 100 % x 30 % = 27 kg

BASIC INFORMATION CONCERNING THE HANDLING OF MAGNETIC LIFTING GEAR – IN PARTICULAR TML MAGNETS

The magnetic surface is located on the underside of the lifting magnet incorporating different magnetic poles which generate the magnetic holding force through magnetic flux when activated. The maximum holding force that can be achieved depends on different factors which are explained below:

Material thickness

The magnetic flux of the lifting magnet requires a minimum material thickness to flow completely into the load. Below this minimum thickness of material, the maximum holding force is reduced subject to material thickness. Conventional switchable permanent magnets have a deeply penetrating magnetic field (similar to tree tap roots) and require a large material thickness to achieve maximum holding force. The magnetic field of the TML magnets is very compact, similar to a shallow root, so that maximum holding force is achieved even when used on thin materials (see performance data in table 2 and 3).

Material

Every material reacts in a different way to penetration of the magnetic field lines. The load-bearing capacity of the TML lifting magnets is determined using an S235 material. Steels with high carbon content or whose structure has been changed by heat treatment have a low holding force. Foamed or porous cast components also have a lower holding force, so that the given load-bearing capacity of the lifting magnet can be downgraded on the basis of the following table 1.

Table 1

Material	Magnetic force in %
Non-alloyed steel (0.1-0.3% C content)	100
Non-alloyed steel (0.3-0.5% C content)	90-95
Cast steel	90
Grey cast iron	45
Nickel	11
Stainless steel, aluminium, brass	0

Surface quality

The maximum holding force of a lifting magnet can be achieved in case of a closed magnetic circuit in which the magnetic field lines can connect up freely between the poles, thus creating a high magnetic flux. In contrast to iron, for example, air has very high resistance to magnetic flux. If a kind of "air gap" (i.e. a space) is formed between the lifting magnet and the work piece, the holding force will be reduced. In the same way, paint, rust, scale, surface coatings, grease or similar substances all constitute an air gap, between work piece and lifting magnet. An increase in surface roughness or unevenness also has an adverse effect on the magnetic holding force. Reference values can be found in the performance data of your lifting magnet (see table 2 and 3).

Load dimensions

When working with large workpieces such as girders or plates, the load can partly become deformed during the lift. A large steel plate would bend downwards at the outer edges and create a curved surface which no longer has full contact with the bottom of the magnet. The resulting air gap reduces the maximum load-bearing capacity of the lifting magnet. In contrast to this, nor should objects be hollow or smaller than the magnetic surface, as otherwise the entire power of the lifting magnet will not be used.

Load alignment

During load transport care must be taken that the lifting magnet is always at the centre of gravity of the work piece and that load, or lifting magnet respectively, is always aligned horizontally. In this case, the magnetic force of the lifter acts with its full breakaway force at right angles in relation to the surface and the maximum rated load-bearing capacity is achieved through the 3:1 standard safety factor. If the position of work piece and lifting magnet changes from horizontal to vertical, the lifting magnet is operated in shear mode and the work piece can slip away to the side. In shear mode, the load-bearing capacity decreases dependent upon the coefficient of friction between the two materials.

Temperature

The high-power permanent magnets installed in the lifting magnet irreversibly lose their magnetic properties from a temperature of more than 80°C, so that the full load-bearing capacity is never reached again even after the magnet has cooled down. Please note the specifications on your product or in the operating manual.

MAINTENANCE AND INSPECTION OF THE LIFTING MAGNET

The user is obliged to maintain and service the lifting magnet in compliance with the specifications in the operating manual and according to the country-specific standards and regulations (e.g. ASME B30.20B, DGUV-Information 209-013; AMVO).

The maintenance intervals are classified according to the recommended schedule. If one of the faults listed should occur, please proceed as follows:

Before every use...

- visually inspect the lifting magnet for damage
- clean the surface of the workpiece and the underside of the magnet
- free the underside of the magnet of rust, chips or unevenness

Weekly...

- inspect the lifting magnet for deformation, cracks or other defects
- make sure the activation lever is working properly and latches correctly into place
- inspect the load swivel for damage, deformation, cracks or wear and have it replaced if necessary
- inspect the bottom of the magnet for scratches, pressure points or cracks and have the magnet repaired by the manufacturer if necessary

Monthly...

- check the markings and labelling on the lifting magnet for legibility and damage and replace them if necessary

Annually...

- have the load-bearing capacity of the lifting magnet checked by the supplier or an authorised workshop

An annual inspection is recommended for the triple safety system of this lifting magnet.
We will be glad to assume this inspection for you first-hand.
Please send us an email to:

TML-Test@alfra.de

You will then promptly receive an offer and have the assurance that the lifting magnet will be inspected in a process-reliable manner where it was actually produced.



**Unauthorised repairs or modification to the lifting magnet are not permitted.
If you have any questions contact the manufacturer.**

DETAILED PERFORMANCE DATA FOR THE TML 90 R LIFTING MAGNET ON FLAT MATERIAL

Values shown for load capacity of the TML 90 R are based on material S235 JR for the maximum, vertical tractive force with 0° deviation from the load axis and additionally under a 6° inclined load in accordance with EN13155, in each case with a 3:1 safety factor.

Table 2: Flat material

Load capacity in kg						
Thickness of material	Clean, flat, ground surface		Rusty, slightly scratched surface		Irregular, rusty or rough surface	
	Air gap <0.1 mm		Air gap = 0.25 mm		Air gap = 0.5 mm	
mm	0°	6°	0°	6°	0°	6°
2	27	24	23	20	20	17
3	45	41	36	32	32	28
4	72	65	54	49	41	36
5	86	77	63	57	45	41
6	90	81	63	57	45	41
>6	90	81	63	57	45	41

Load capacity in lbs						
Thickness of material	Clean, flat, ground surface		Rusty, slightly scratched surface		Irregular, rusty or rough surface	
	Air gap <0.004 inches		Air gap = 0.01 inches		Air gap = 0.02 inches	
inch	0°	6°	0°	6°	0°	6°
0.08	59	53	50	44	45	41
0.12	99	89	81	73	68	60
0.16	162	146	117	105	90	81
0.20	189	170	140	125	99	89
0.25	200	178	140	125	99	89
>0.25	200	178	140	125	99	89

The maximum dimensions of the loads to be lifted depend to a large extent on the geometry and flexural stiffness of the work pieces, since, in case of bending, an air gap forms under the magnetic surface and the load-bearing capacity decreases significantly. During each lift, watch for any deformation of the work piece that might occur and, if necessary, check for any air gap developing at the edges of the TiN-coated magnetic surface (e.g. with a sheet of paper; 80g/m²).

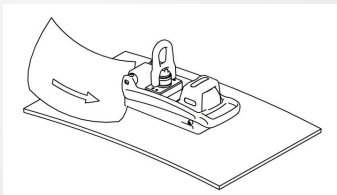

Immediately stop the lift if there is any excessive deformation or an air gap.







Never exceed the dimensions and/or the load-bearing capacity of the material thickness given in table 2.

DETAILED PERFORMANCE DATA FOR THE TML 90 R LIFTING MAGNET ON ROUND PIPES

Values shown for load capacity of the TML 90 R are based on material S235 JR for the maximum, vertical tractive force with 0° deviation from the load axis and additionally under a 90° inclined load. The safety factor corresponds to at least 3:1 in all cases.

Table 3: Round pipes

mm	Load capacity in kg					
	25	50	75	100	200	
	5	30	40	45	40	-
	4	27	36	42	36	-
	3	26	34	40	34	-
	2	24	32	38	32	-

Inch	Load capacity in lbs					
	1"	2"	3"	4"	8"	
	0.2	66	88	100	88	-
	0.16	59	79	92	79	-
	1/8	56	75	88	75	-
	0.08	53	70	83	70	-



Avoid quick and abrupt rotations of the lifting magnet especially when used on round objects since the workpiece could disengage from the groove of the magnet and the load-bearing capacity would suddenly be reduced.



Never exceed the dimensions and/or the load-bearing capacity of the material thickness given in table 2 & 3.

EC DECLARATION OF CONFORMITY AS DEFINED BY THE MACHINERY DIRECTIVE 2006/42/EC

We,

Alfra GmbH
2. Industriestr. 10
68766 Hockenheim/Germany

hereby declare that the switchable permanent magnet-type lifting magnet
TML 90 R with mounted TMC 300 R
from serial number **1583F0256** onwards

complies with the following standards:

EN ISO 12100:2010
EN 13155:2003+A2:2009

This certificate is no longer valid if the product is modified without the manufacturer's consent. Furthermore, this certificate is no longer valid if the product is not used properly in accordance with the use cases documented in the user manual or if regular maintenance is not carried out in accordance with this manual or country-specific regulations.

Person authorised to compile the documents:

Alfra GmbH
2. Industriestr. 10
68766 Hockenheim/Germany

Hockenheim/Germany, 03.04.2017

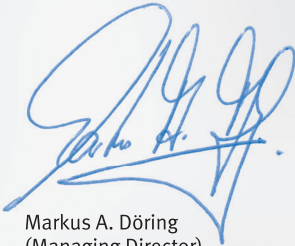

Markus A. Döring
(Managing Director)