

# Grade-10 Swivel Eyenuts

## Product Description

- Forged from high tensile alloy steel
- Tempered
- 100% electromagnetic crack testing to AS1171
- Hi-visibility powder coating to AS4506
- Manufactured exclusively from Australian Made Steel
- Long shanks and special thread forms made to order

Please ensure that all information contained in this user guide has been read and understood prior to the safe use of the Grade-10 Lifting Eyenut. Failure to follow this guide may result in serious injury and/or property damage. Failure to follow this user guide voids the manufacturer's warranty.



This document may refer to the Eyenut as the Lifting Point

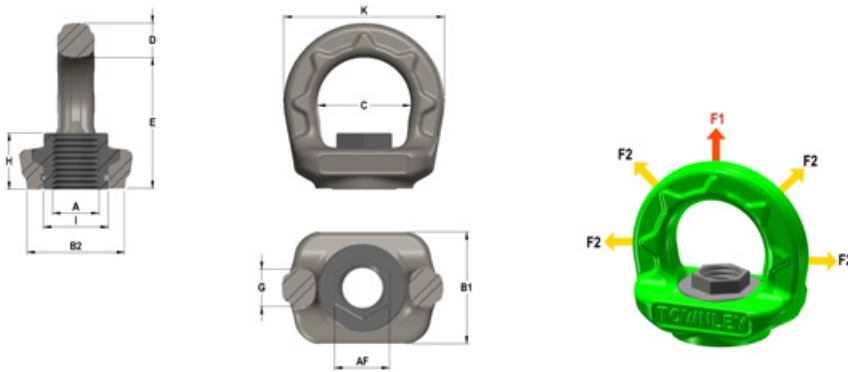

Townley Drop Forge maintains a NATA Accredited Laboratory (Test Lab No. 13554) and an AS/NZS ISO9001 Certified QMS (Certificate number FS 604897)

A Imperial	A Metric	WLL F1	WLL F2	B1	B2	C	D	E	G	H	I	K	AF	Weight (kg)
5/16"	M08	1t	0.3t	33	30	30	11	43	11	18.5	18	55	16	0.23
3/8"	M10	1t	0.4t	33	30	30	11	43	11	18.5	18	55	16	0.23
1/2"	M12	2t	0.75t	33	30	30	11	43	11	18.5	18	55	16	0.23
5/8"	M16	4t	1.5t	39	35	34	14	49	14	21	22	64	18	0.38
3/4"	M20	6t	2.3t	48	42	39	16	56	16	25	28	69	24	0.60
7/8"	M22	7t	2.3t	48	42	39	16	56	16	28	28	69	24	0.72
1"	M24	8t	3.2t	56	50	50	19	71	19	28	33	86	27	1.10
1.1/8"	M27	8t	3.2t	56	50	50	19	71	19	28	33	86	27	1.80
1.1/4"	M30	12t	4.5t	69	60	60	22	85	22	32	42	110	34	1.90
1.1/2"	M36	16t	7t	85	76	70	29	100	29	37	50	132	41	4.00
1.3/4"	M42	24t	9t	110	100	95	38	132	38	45	69	179	55	7.80
2"	M48	32t	12t	110	100	95	38	132	38	48	69	179	55	8.20

### WLL (WORKING LOAD LIMIT)

Each Eyenut is clearly stamped with the permitted F2 WLL.

**F2 WLL** - indicates safe use for non-axial lifts.

**F1 WLL** - indicates loads which are in line with the axis of the threaded end of the eyenut. F1 WLL allows up to four (4) times higher lifting capacity whilst maintaining a 4:1 design factor of safety.