

# Safety Latch Kits - ELD Hooks

## Product Description

- Replacement Safety Latches
- Available for Shank, Swivel and Eye Hooks
- Designed to suit ELD Hooks



Townley Drop Forge maintains a NATA Accredited Laboratory (Test Lab No. 13554) and an AS/NZS ISO9001 Certified QMS (Certificate number FS 604897)

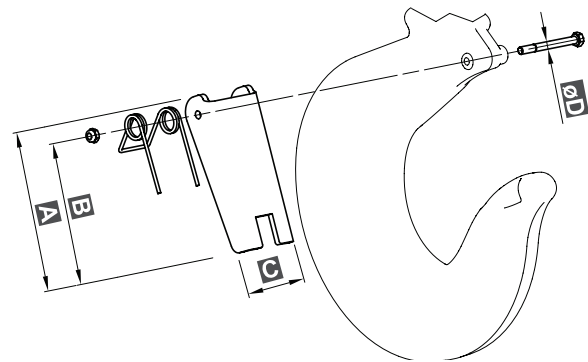

### Dimensions: Safety Latch Kits – ELD

Code	A	B	C	D	WLL
2DS0D1	39.5	32.5	17	4	1.25
2DS0D2	43.5	35.5	23	4	1.6
2DS0D3	49	41	25	4	2.5 + 3.2
2DS0D4	61.5	51.5	29	5	5.4
2DS0D5	77.5	67.5	35	5	8
2DS0D6	87	76	37	6	11.5
2DS0D7	96	85.5	49	6	16
2DS0D8	131	116	54	6	22
2DS0D9	152.5	135	64	8	31.5