

Swivel Hook Heavy Duty

Product Description

- ✓ Forged - hardened and tempered
- ✓ Heavy duty bearings
- ✓ Load rated
- ✓ Meets requirements of ASME B30.10 and EN 1677



Townley Drop Forge maintains a NATA Accredited Laboratory (Test Lab No. 13554) and an AS/NZS ISO9001 Certified QMS (Certificate number FS 604897)

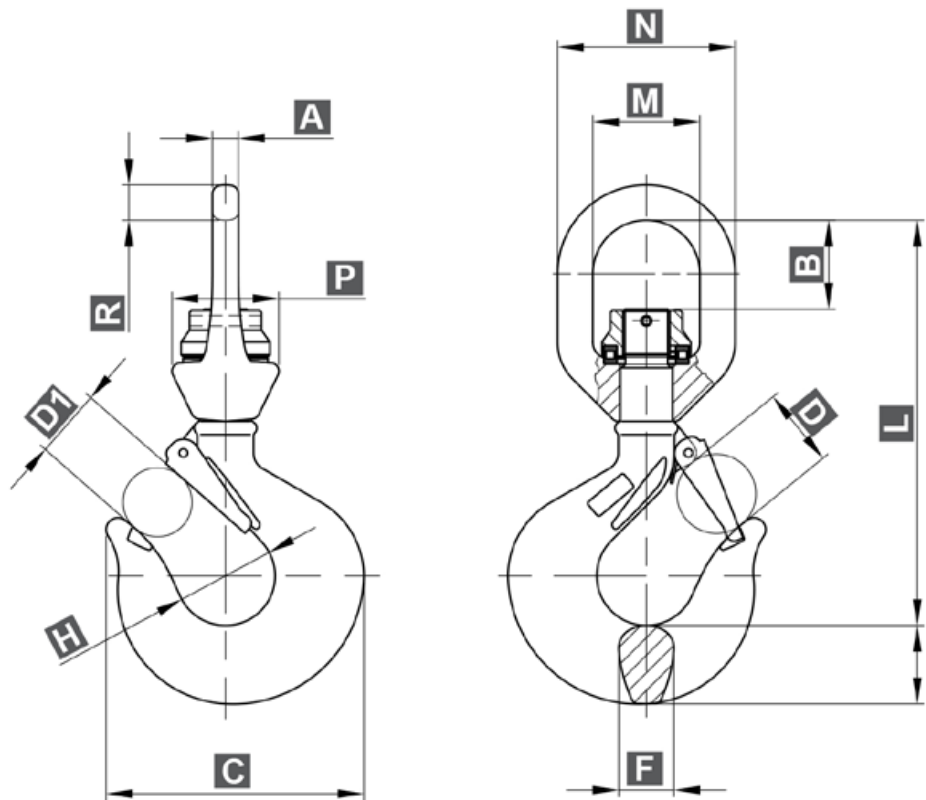

Dimensions and Working Load Limits

Part No.	WLL	Grade	Chain (mm)	A	B	C	D	D1	E	F	H	L	M	N	P	R	Weight (kg)
SSH800	8t	8	16	17.5	65	165	51	43	49	37	62	266	72	120	70	24	5.87
SSH1150	11.5t	8	19	22	68	198	58	53	60	43	75	310	82	136	82	27	9.75
SSH1600	16.0t	8	22	24	84	222	66	58	67	52	84	352	92	154	92	31	15.30
SSH2200	22.0t	8	26	29	107	283	87	78	80	64	110	434	115	191	108	38	26.50
SSH3150	31.5t	8	32	34	117	339	97	87	94	80	120	512	132	222	132	45	50.00