

Grade-8 Eyebolts

Product Description

- Forged from high tensile alloy steel
- Tempered
- Electromagnetic crack testing to AS1171
- Hi-visibility powder coating to AS4506
- Manufactured from Steel certified to Australian Standards
- Long shanks and special thread forms made to order

Please ensure that all information contained in this user guide has been read and understood prior to the safe use of the Grade-8 Lifting Eyebolt. Failure to follow this guide may result in serious injury and/or property damage. Failure to follow this user guide voids the manufacturer's warranty.

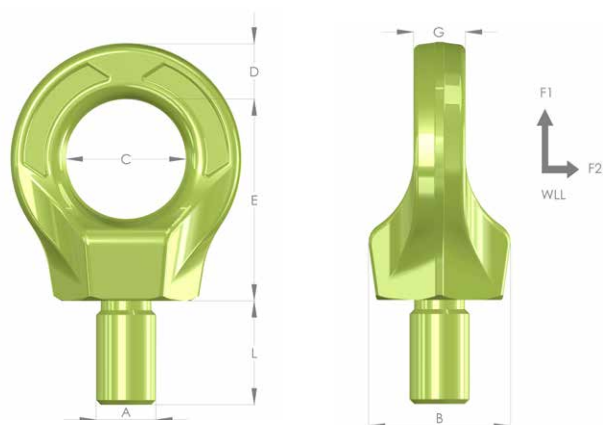

Townley Drop Forge maintains a NATA Accredited Laboratory (Test Lab No. 13554) and an AS/NZS ISO9001 Certified QMS (Certificate number FS 604897).

| A Imperial (") | A Metric | WLL F1 (t) | WLL F2(t) | B | C | D | E | G | L | Weight (kg) |
|-------------------|-------------|---------------|--------------|----|----|----|-----|----|----|----------------|
| 5/16 | M08 | 0.8 | 0.2 | 27 | 30 | 12 | 48 | 10 | 21 | 0.19 |
| 3/8 | M10 | 1 | 0.25 | 27 | 30 | 12 | 48 | 10 | 21 | 0.19 |
| 1/2 | M12 | 1.6 | 0.4 | 27 | 30 | 12 | 48 | 10 | 21 | 0.19 |
| 5/8 | M16 | 4 | 1 | 34 | 34 | 15 | 55 | 14 | 28 | 0.33 |
| 3/4 | M20 | 6* | 1.6 | 41 | 40 | 17 | 70 | 16 | 35 | 0.68 |
| 7/8 | M22 | 7* | 2 | 50 | 49 | 20 | 83 | 20 | 42 | 1.1 |
| 1 | M24 | 8* | 2.5 | 50 | 49 | 20 | 83 | 20 | 42 | 1.1 |
| 1.1/8 | M27 | 8* | 2.5 | 50 | 49 | 20 | 83 | 20 | 42 | 1.1 |
| 1.1/4 | M30 | 12 | 3 | 71 | 60 | 28 | 101 | 26 | 52 | 2.3 |
| - | M33 | 16 | 4 | 71 | 60 | 28 | 101 | 26 | 52 | 2.3 |

WLL (WORKING LOAD LIMIT)

Each eyebolt is clearly stamped with the permitted F2 WLL.

F2 WLL - indicates safe use for non-axial lifts.

F1 WLL - indicates loads which are in line with the axis of the threaded end of the eyebolt. F1 WLL allows up to four (4) times higher lifting capacity whilst maintaining a 4:1 design factor of safety.

* Please note, not 4 times.

Subject to technical modifications