

GEOMET® Height Safety Anchor Point

Product Description

Welcome to the world of GEOMET®, a cutting-edge zinc flake coating technology designed to offer unparalleled corrosion and chemical resistance for a wide range of industrial applications.

Load Ring:

- Rated Capacity: 1 - 2 Persons
- Alloy steel construction
- Long and short series bolt options
- Non-removable bolt
- 100% Crack Detection
- Made in Australia
- AS/NZS 5532:2013

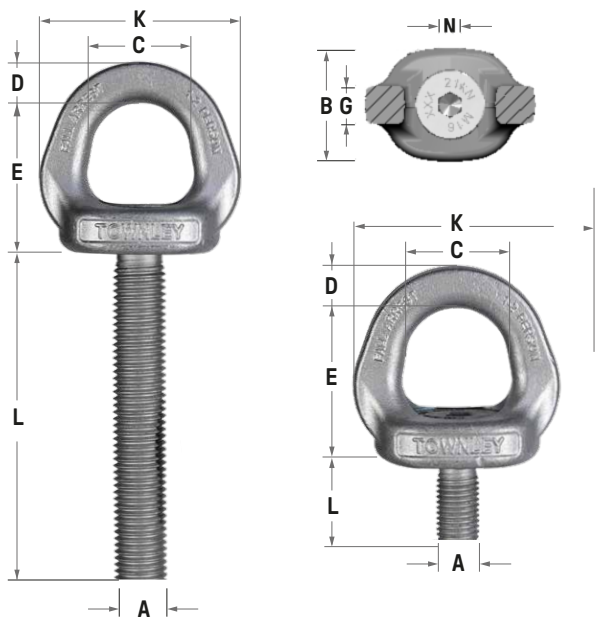

Product Code	A	B (mm)	C (mm)	D (mm)	E (mm)	G (mm)	K (mm)	L (mm)	N (mm)	Weight (kg)
FP-G-TSEB16	M16	50	39	16	55	16	75	30	12	0.4
FP-G-TSEB16-60	M16	50	39	16	55	16	75	60	12	0.4
FP-G-TSEBLS16	M16	50	39	16	55	16	75	180	12	0.6
FP-G-TSEB20	M20	50	39	16	55	16	75	30	12	0.6
FP-G-TSEB20-60	M20	50	39	16	55	16	75	60	12	0.6
FP-G-TSEBLS20	M20	50	39	16	55	16	75	180	12	0.8

GEOMET®

WASCA

(03) 9763 0833 WASCA.COM.AU

Advanced Zinc Flake coating technology offering:

- Unparalleled corrosion resistance
- Water Based, chromium & PFAS free
- Applied by Australia's authorised Licensee; WASCA

GEOMET® is a registered trademark of NOF Metal Coatings

Important:

All persons using this equipment must read and understand all instructions outlined in this document. Failure to do so may result in serious injury or death. Only to be used by competent persons who can provide proof of competency training by a registered training organisation. Training shall be in accordance with the relevant Australian standards that govern industrial fall arrest systems and devices.

**DON'T RISK IT, CHOOSE
TOWNLEY**

DISTRIBUTORS THROUGHOUT AUSTRALIA & NEW ZEALAND